

KmN 1.4sm

VersaMobile

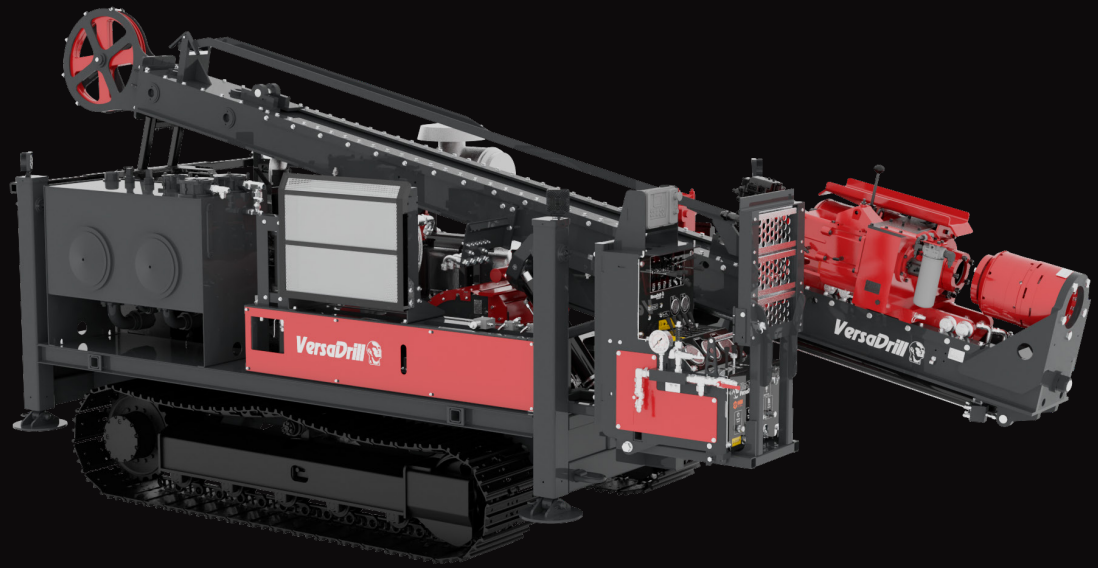

SPECIFICATIONS

Rotary head and chuck	
Holding capacity	38,000 lbs (17,236 kg)
Spindle interior dimension	4.9 in (124 mm) PWL rod
Chuck operation	Spring closed and hydraulically opened
Final drive	HV 80-3 chain in an oil bath
Hydraulic motor	160 cc variable
Transmission	HI-LO 2-speed mechanic
Rotary head ratio	1:2.33
Lubrication	Pump pressurized, filter and cooler
Speed	0 to 1250 rpm

FEATURES AND BENEFITS

- Design optimized for surface operation with low ground pressure
- Depth capacity:
1,400 m (4,600 ft) N size
- Total weight:
23,450 lbs (10,660 kg)

kmN 1.4sm

SURFACE DRILL

Filtration

10 micron absolute filter on return line (2)
High pressure filter (2)
One strainer inside the hydraulic tank connected to the suction (2)

Hydraulic module

Floating rotary head - Torque limit on rotary head	
Hydraulic pumps (2)	246 l/min (65 US gal/min) @ 1 800 RPM (max. 4 000 psi (275 bar)) 136 l/min (36 US gal/min) @ 1 800 RPM (max. 4 000 psi (275 bar))
System drive	Open loop, Load-sensing circuit
Hydraulic variable reservoir	3.7 US gal. (14 l)
Oil heat exchanger	Air cooling (water cooler optional)

Weight

Frame and track w/ power unit	33 080 lbs (15 005 kg)
Drill unit: KmN 1.4U (light version/alu)	5 600 lbs (2 540 kg)

Drilling capacity

*Recommended size for maximum performance	*B 2 3/16" (55,6 mm)	6 230 ft (1 900 m)
	*N 2 3/4" (69,9 mm)	4 600 ft (1 400 m)
	*H 3 1/2" (88,9 mm)	2 625 ft (800 m)
	P 4 5/8" (117,5 mm)	1 610 ft (500 m)

Drilling capacity is calculated on a 90-degree down hole and will depend on in-hole tools, ground conditions, drilling techniques and equipment used.

Recommended diesel engine: 235 hp (175 kW) at 2 100 rpm

Feed frame

Head stroke	5 ft 6 in (1.68 m)
Raising speed	143 ft/min (43 m/min)
Lowering speed	143 ft/min (43 m/min)
Pull capacity	26 000 lbs (11 800 kg) @ 4 000 psi
Push capacity	26 000 lbs (11 800 kg) @ 4 000 psi
Possible angle	-45 to -90 degrees

Surface mast

Pull speed	150 ft/min (45 m/min)
Speed of descent	100 ft/min (30 m/min)
Single line pull capacity	2 200 lbs (1 000 kg) @ 3 000 psi
Rod pull length	20 ft (6 m)

2-Speed transmission

Speed	Ratio	RPM	Maximum Torque
LO	3.46:1	0-361	4 196 lb*ft (5 689 N*m) @ 361 RPM
HI	1:1	0-1 250	1 213 lb*ft (1 644 N*m) @ 1 250 RPM

Speed and torque based on a 160 cc hydraulic motor at 4 000 psi (275 bar)

Wireline hoist

Cable capacity (3/16 in - 4.8 mm)	6 890 ft (2 100 m)
Empty Pull capacity	2 000 lb (907 kg)
Full Pull capacity	650 lb (295 kg)
Variable speed as needed	

DIMENSIONS

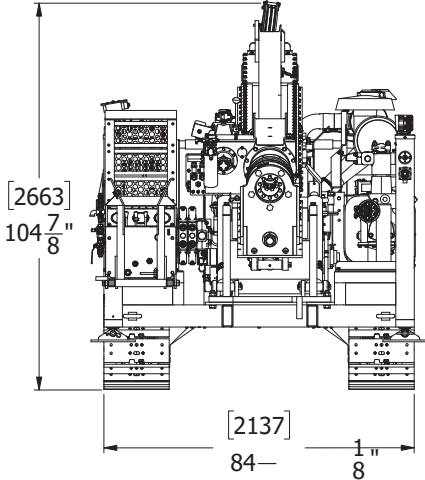
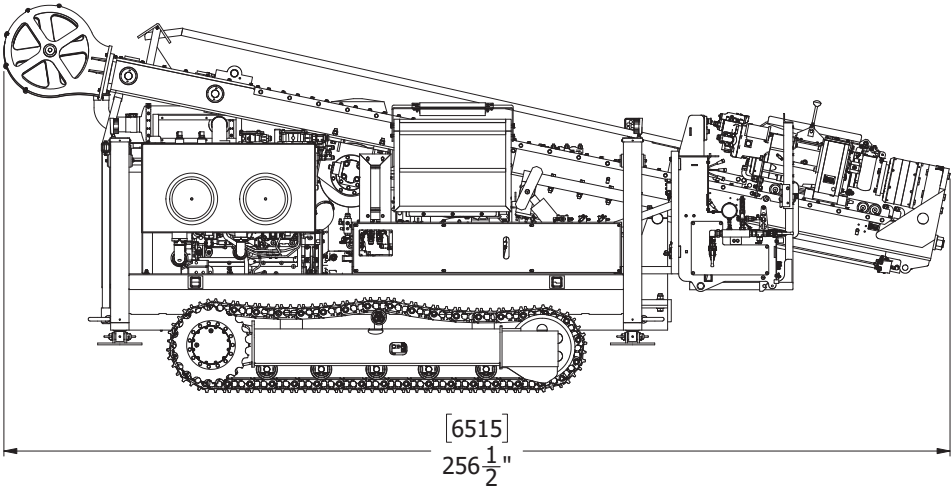
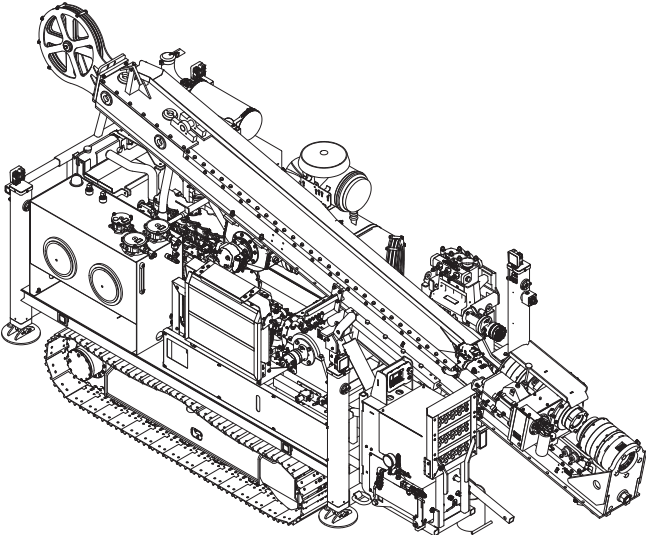

STRONGER AND STRONGER

Distributor:



110 Jacques-Bibeau St., Rouyn-Noranda, QC J9Y 0A3, Canada

1 819 762-9645 info@mbiglobal.ca